

HALUX N50-3 P SX

TECHNICAL DATA

FITTED WITH	1 x LED module
LUMINOUS POWER	50 000 lux / 0.5 m *
ILLUMINANCE FIELD 0.5 m	Ø 18 cm (7.1 in.) *
COLOR RENDERING INDEX	CRI > 93
COLOR TEMPERATURE	3 300 K / 3 800 K / 4 400 K*
OPERATION EQUIPMENT	Electronic converter
VOLTAGE	100-240 V; 50/60 Hz
CORD LENGTH	1.8 m (10 ft.) *
LUMINAIRE BODY	Polycarbonate (PC) & acrylonitrile butadiene styrene copolymer (ABS)
WEIGHT (NET)	1.3 kg (2.9 lbs.)
POWER CONSUMPTION	18 W
USAGE	Touch panel on light head
BALANCE OF ARTICULATION JOINTS	Friction
CLASS OF PROTECTION	II
PROTECTION RATING	IP 20
STANDARDS MET	EN 60601-1, EN 60601-2-41
SPECIAL FEATURES	3 color temperatures, 5 dimming levels, maintenance-free
MOUNTING	Mounting pin (Ø 16 mm)
ACCESSORIES	Rolling floor stand, rail mounting with removal guard, table clamp with removal guard, universal mount with removal guard, extension arm with removal guard, wall mount with removal guard
ORDER NUMBER	D16.011.000-00806680 - pure white - Euro D16.036.000-00806684 - pure white - UK

EXAMINATION LIGHTS



LIGHT DISTRIBUTION

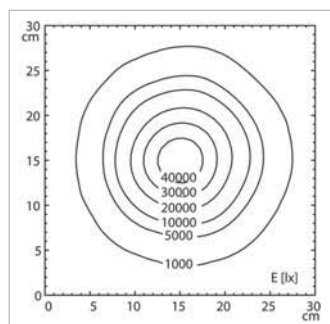
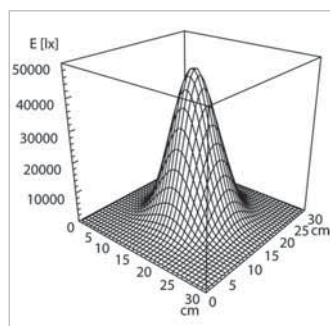

TECHNICAL DRAWING

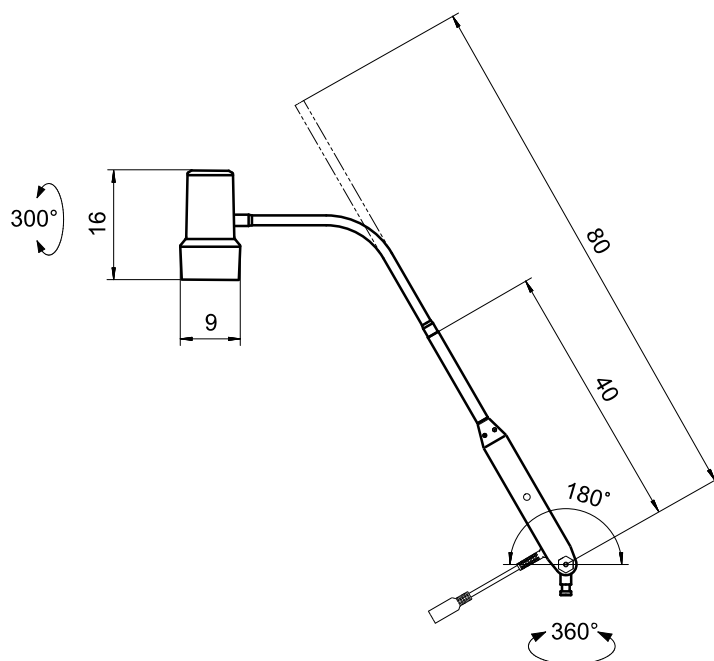

measurements in centimeters

* -10% / +20% tolerance